

DDC



Pulpmatic Ultima Medical Pulp Macerator

Designed to pulverise and dispose of both single-use medical pulp containers and human waste, DDC's range of PULPMATIC® bedpan macerators are the sluice room equipment of choice for thousands of healthcare facilities around the world.



Redefining Infection Control

Medical Pulp Macerators provide a robust and hygienic solution for the complete disposal of human waste. The pulp container along with its contents can be placed inside the macerator without the need to wash or dispose of items elsewhere.

They are then quickly and effectively pulverised into tiny particles using advanced maceration technology and discharged directly into the main sewage system, meaning that any infectious materials can no longer come into contact with patients or clinicians.

The Pulpmatic Ultima is our largest capacity medical pulp macerator, suitable for busy wards and care homes, capable of disposing of up to 6 pulp items per cycle.

The unique nine bladed macerator technology allows for a rapid disposal cycle of just 120 seconds, without compromising on efficiency, water usage or noise levels.



DDC Dolphin's range of Pulpmatic Pulp Macerators underpin the infection control strategy of thousands of facilities around the world.

Key Benefits

- Reduce cross contamination of infectious materials and minimise the risk of ward outbreaks, keeping staff and patients safe.
- Save clinicians' time and increase productivity by reducing the need for cleaning of reusable items.
- Exceptionally economical, using little water and energy to operate.
- Reduce hospital budget spend with low operating costs and prevention of ward shutdowns due to infections.

Pulpmatic Ultima Features



Large capacity machine
Suit high usage environments.



Antimicrobial surfaces
To minimise cross infection and reduce the possibility of microbial growth.



Rapid cycle
Less than 2 minute cycle to dispose of up to 6 pieces of pulp.



Compact
Save space, making it suitable for all room types and sizes.



Advanced 9 bladed technology
Pulverises pulp utensil into tiny particles, ensuring all waste is eliminated.



Contactless technology
Reducing infection risk for clinicians and patients.



Continuous, free-flowing output of waste to drain
Ensuring thorough removal of waste.



High quality materials and components
Smooth, crevice-free surfaces to minimise trapped bacteria.



Various start options
To suit each facility's requirements, ranging from self to auto start.



Optional bespoke noise reduction kits available
To ensure machines are suitable for quieter environments such as isolation wards.



Optional programmable audio*
Language specific to ensure correct and proper use by staff.



Pre- & post-maceration self-cleaning flush
To limit the residual build up within the waste pipe network and abolish blockages.



Automatic drain flush
Can be programmed during low use times to limit the build-up of stagnant water and remove the possibility of Legionnaires' disease.

*Optional feature. Available in various languages—contact our team for more information.



Technical Specifications

GENERAL	
Stainless Steel grade:	304
Dimensions w x h x d (lid closed):	500 x 1042 ±3 x 600mm
Weight (Machine Only):	Dry 85kg Wet 108.5kg
Capacity:	4 to 6 pieces of medical pulp
Ingress protection:	IP22
Operation cycle time:	<120 seconds
Decibel rating:	<70dba
DISINFECTION	
Recommended chemical:	Aqua Clean
Chemical dosing per cycle:	13ml (adjustable to suit efficacy requirements)
ELECTRICAL	
110V Voltage:	110V / 60Hz with dedicated 15A breaker (UL Version)
230V Voltage:	230V / 50Hz with dedicated 13A breaker
Circuit protection (230 Voltage):	30mA RCD, GFI, IEC60364 compliant
Rated power input:	1.1kW
Electrical consumption per cycle:	0.025kWh
Motor power:	0.75kW
Pump power:	0.345kW
Water	
Water connection:	3/4" BSP male fitting required (washing machine hose)
Water pressure:	Cold Water supply pressure 1 – 6 Bar
Water flow rate (Min):	12L per minute at 1 bar
Water tank capacity:	24L
Water consumption per cycle:	26.7L
Waste connection:	50mm ID (2")
Overflow connection:	22mm
Waste Height:	160mm to 250mm – See Installation Preparation Guide for full details.

*Specifications correct at time of print

Dimensions

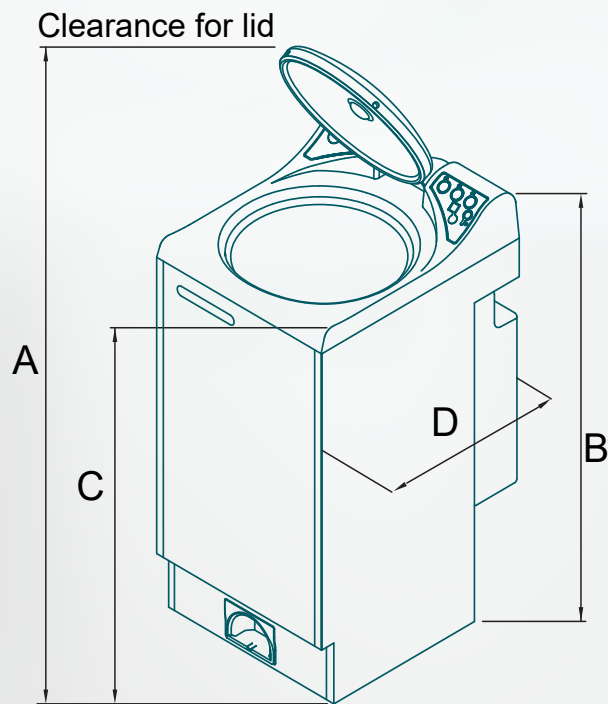

Overflow output can be connected to left or right of the machine

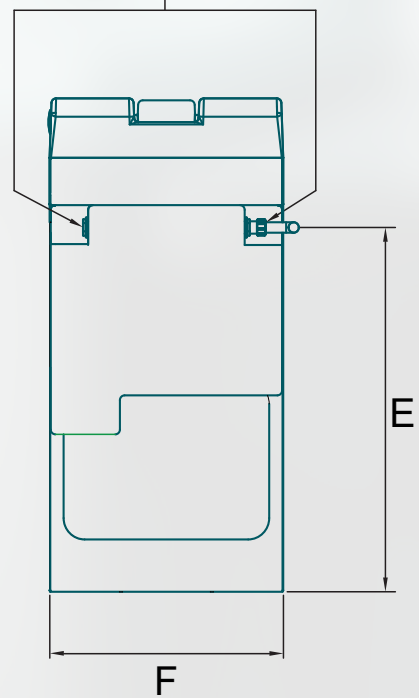

	Milimeters
A	1500 ±3
B	1042 ±3
C	960
D	600
E	766
F	500

DDC



Certificate Number 1151
9001/14001

